

## Metal detector belt BMK 4

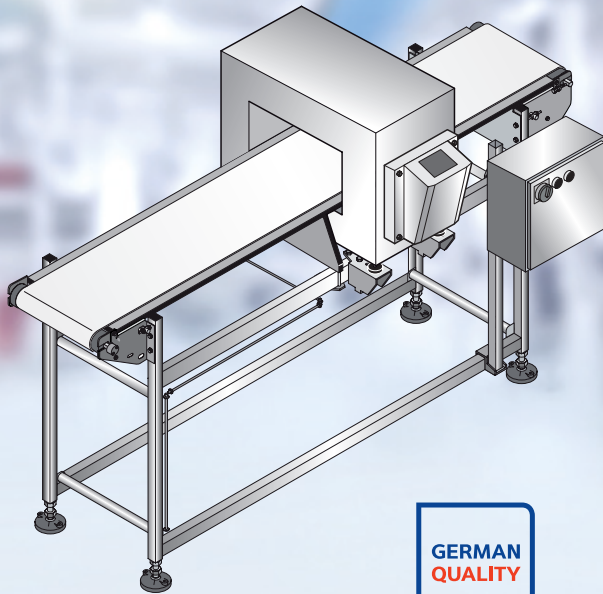

German Quality

### ! Benefits

- Made entirely from stainless steel
- Working heights from 700 - 1100 mm
- Easy to clean
- IFS and BRC compliant
- Detects magnetic metal parts as well as high-alloy steels and non-ferrous metals
- Solid frame made from stainless steel 1.4301
- Diverse function enhancements
- "Made in Germany" quality seal

Amongst other things, the metal detector belt BMK from Minebea Intec was developed for use in production lines of the food industry. It consists of a torsion-free belt structure and has been prepared for a Minebea Intec metal detector.

The metal detector belts BMK, together with the Minebea Intec metal detectors, reach an optimum search sensitivity and are able to detect even the smallest metal foreign objects. Besides magnetic metal parts, high-alloy steels and non-ferrous metals (copper, brass, aluminium, lead) can be verified and separated from the production process with the pusher, blower or other separation mechanisms.

Design and construction fully comply with the requirements of the CE conformity. Furthermore, a simple cleaning process is guaranteed due to a hygienic design and the protection class IP 65 (or higher).

The metal detector belt is entirely made of stainless steel 1.4301 (AISI304) and can be configured with various transport chains.

In-house production using top-quality materials, which bear the "Made in Germany" quality seal, ensures unprecedented product quality.

## Use

Metal detector belts are a standard part of modern production sites of the food industry. They guarantee that products that have been contaminated by foreign objects don't reach the customer and this way contribute to efficient quality management.

Based on a HACCP analysis, metal detector belts are ideal for optimal control and are defined as a CCP (Critical Control Point) in many production lines. With their multitude of options and accessories, they offer the highest safety while at the same time offering easy integration into their production process.

They are highly configurable and allow compliance with or implementation of guidelines of leading chains, as well as standards that have been internationally recognised by GFSI, like:

- IFS version 6 (International Food Standard)
- SQF 2000 (Safe Quality Food Institute)
- BRC (British Retail Consortium)

## Applications

The metal detector belt BMK was designed for various applications in the food industry and offers a range of options that result in a higher safety and higher efficiency for the process.

Many of the functions of the metal detector belt BMK already are part of the minimum requirements of various food safety standards.

This applies in particular to:

- Compressed air monitoring
- Separation monitoring
- Shift register
- Lockable run-off container
- Fill level monitoring
- Signal lights & signal horns
- Remote control

## Technical specifications

| Metal detector belt BMK 4               |  |
|---|--|
| Designation                             | BMK4   |
| Max. belt bearing capacity              | 20 kg  |
| Max. throughput (item/min)              | Depending on the package length L a minimum distance must be kept between the packages according to the box width of the metal detector. The box width depends on detector channel height C. |
| Speed range                             | 0.22 to 1.2 m/s  |
| Installation length                     | 1,100 to 2,800 mm, depending on model, see order sheet   |
| Belt width                              | 100, 150, 200, 300, 400, 500 mm  |
| Conveyor height                         | 700 to 1,100 mm, depending on model, see order sheet   |
| Transport medium                        | Chain link belt  |
| Drives                                  | Gear motor with rotating current 250 W   |
| Supply voltage                          | 230 V with FU<br>230 V/400 V without FU  |
| Power consumption                       | 600 VA   |
| Feed direction                          | Left → right, right → left   |
| Permissible operating temperature range | - 10°C to + 45°C   |
| Product temperature                     | - 20°C to + 45°C   |
| Protection class                        | IP 65  |
| Material                                | 1.4301 stainless steel   |
| Weight                                  | 170 to 300 kg, depending on model, see order sheet   |
| SCCR (Short Circuit Current Rating)     | 5000 A   |
| Inputs                                  | Available  |
| Outputs                                 | Available  |

# Technical diagrams

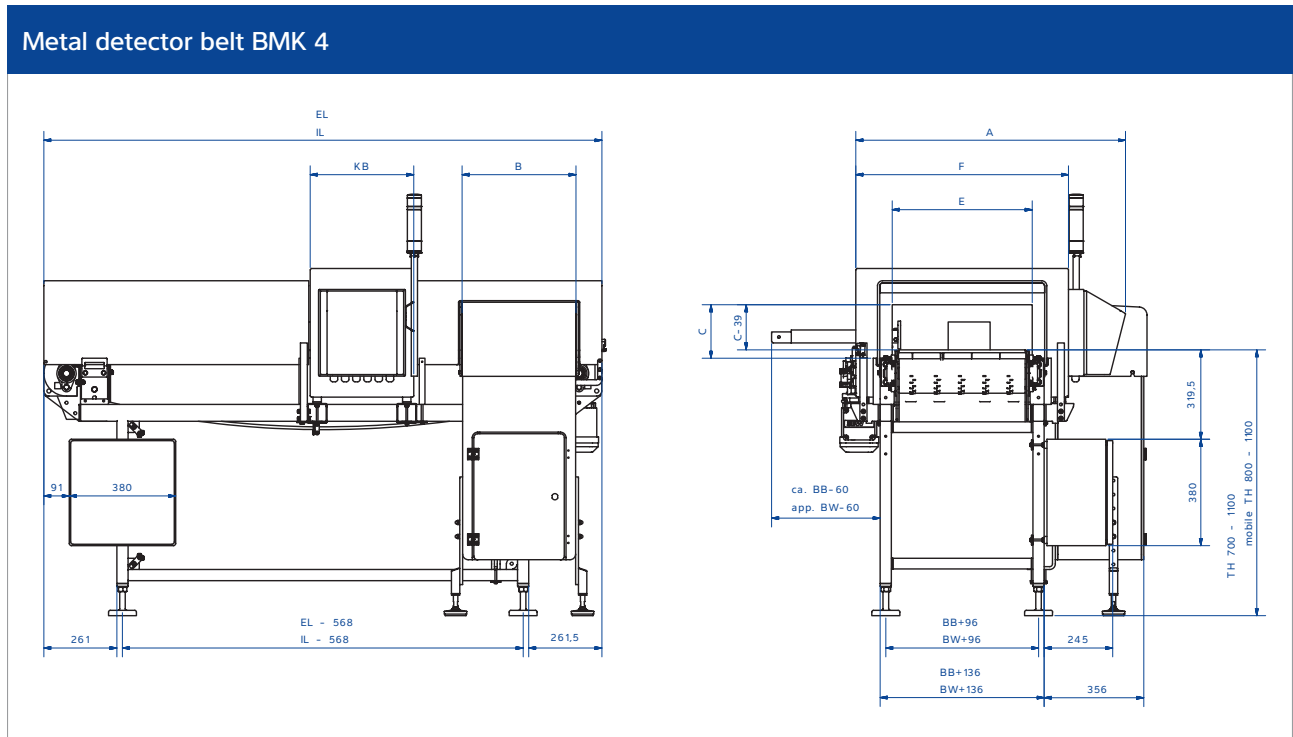

All dimensions in mm

The products and solutions presented in this data sheet make major contributions in the following sectors:



The technical data given serves as a product description only and should not be understood as guaranteed properties in the legal sense.

Specifications subject to change without notice.  
Rev. 08/2018

Minebea Intec Aachen GmbH & Co. KG  
Am Gut Wolf 11  
52070 Aachen, Germany  
Phone +49.241.1827.0  
sales.ac@minebea-intec.com  
www.minebea-intec.com